

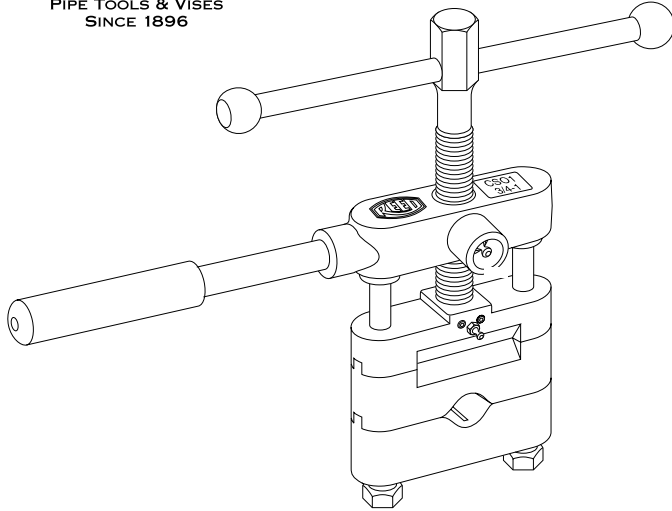

PIPE TOOLS & VISES  
SINCE 1896

## Copper Shut-Off Tool Operating Instructions

CSO1 & CSO2



**CSO1** 3/4" - 1" (19-25 mm)

**CSO2** 1 1/4" - 2" (32-51 mm)

**Shutting off flow:** Assemble tool handle where desired. Unscrew the main feed screw. Lift and swing out dies to allow tube to seat between crimping dies. Swing dies back over the tie rods. Turn the feed screw to compress the tube using only enough pressure to shut off flow.

**Restoring flow:** Remove tool, swing 90 degrees, and reattach so the reforming die slots are seated over the edges of the crimped tube. Turn the feed screw to compress the reforming dies and restore flow. Expect 70 - 75% return of flow.

**Note:** Use the grease fittings inside the front handle hole and at the top crimp bar for lubricating the feed screw and the thrust washer.

Reed Manufacturing Company  
1425 West 8th St.  
Erie, PA 16502 USA



Phone: 800-666-3691 or 814-452-3691  
Fax: 800-456-1697 or 814-455-1697  
[www.reedmfgco.com](http://www.reedmfgco.com)

203 - #50399