



PIPE TOOLS & VISES
SINCE 1896

PE Pipe Peeler (PEPEEL6)

Replacement Parts

Previously known as PESCRAPER2

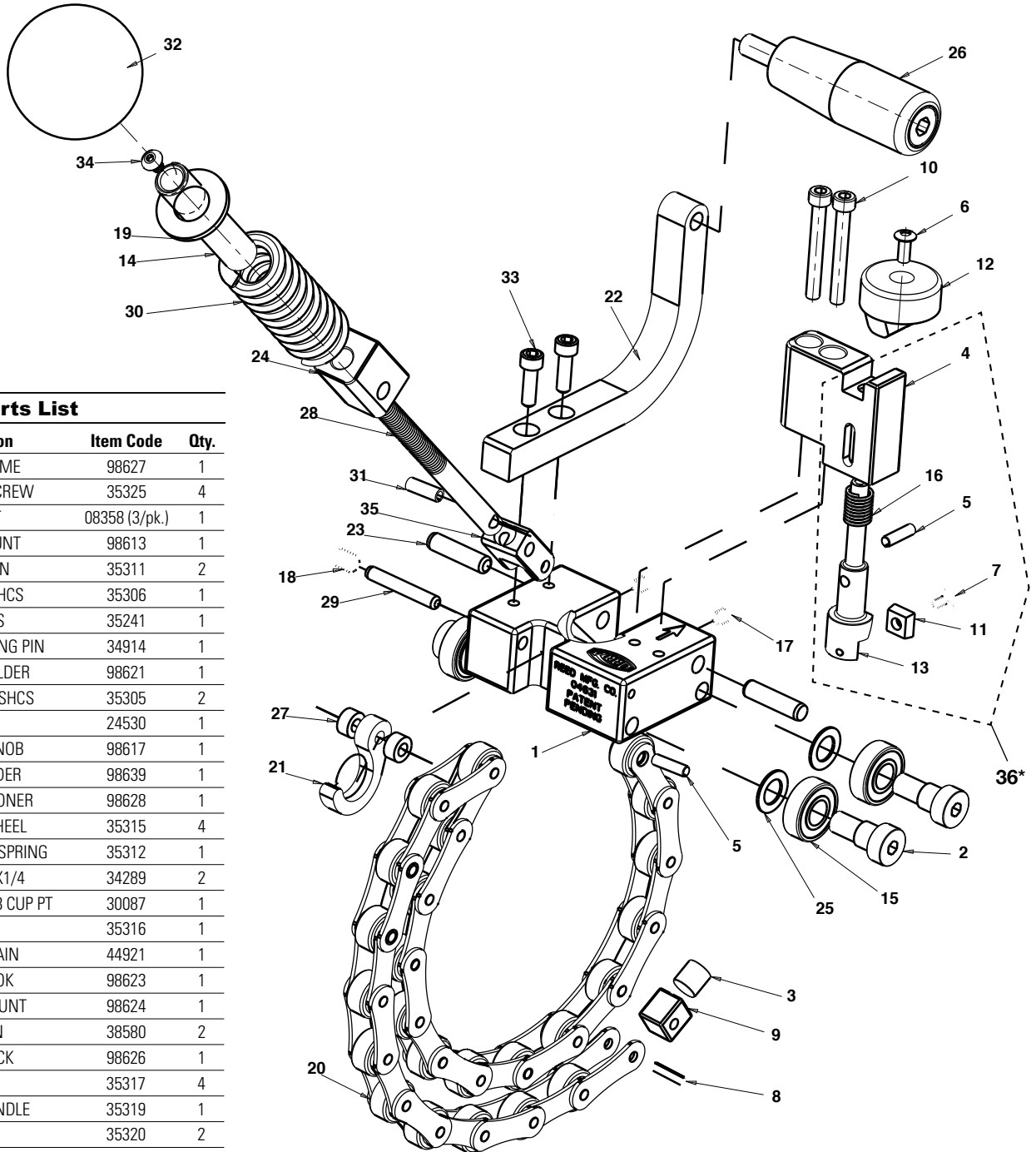

Parts List

Ref. No.	Description	Item Code	Qty.
1	PEELER FRAME	98627	1
2	SHOULDER SCREW	35325	4
3	MAGNET	08358 (3/pk.)	1
4	BLADE MOUNT	98613	1
5	SPRING PIN	35311	2
6	8-32 x 3/8 BHCS	35306	1
7	4-40 FHCS	35241	1
8	1/8 x 9/16 SPRING PIN	34914	1
9	MAGNET HOLDER	98621	1
10	10-24 x 1-1/2 SHCS	35305	2
11	BLADE	24530	1
12	CONTROL KNOB	98617	1
13	BLADE HOLDER	98639	1
14	CHAIN TENSIONER	98628	1
15	BEARING WHEEL	35315	4
16	COMPRESSION SPRING	35312	1
17	SHSS 10-24X1/4	34289	2
18	SHSS 1/4-20X3/8 CUP PT	30087	1
19	WASHER	35316	1
20	ROLLER CHAIN	44921	1
21	CHAIN HOOK	98623	1
22	HANDLE MOUNT	98624	1
23	PIVOT PIN	38580	2
24	PIVOT BLOCK	98626	1
25	SHIM	35317	4
26	TAPERED HANDLE	35319	1
27	SPACER	35320	2
28	TENSIONING SCREW	98625	1
29	DOWEL PIN	35321	1
30	DIE SPRING	35322	1
31	ROLL PIN	35323	1
32	KNOB	35318	1
33	SHCS #10-24 X 5/8 LG	39200	2
34	#8-32 X 1/4 BHCS	35313	1
35	CHAIN CLEVIS	98643	1
36*	BLADE ASSEMBLY	04633	1

*May be used on all #04631 models, including those manufactured before June 2016. For the older style units, allows the conversion to the current Blade Assembly style which is now #04633.

Old style Blade Assembly for units manufactured before June 2016

Screw #7 - #35307

Blade #11 - #98612

Blade Holder #13 - #98616

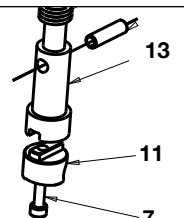

Reed Manufacturing Company
1425 West 8th Street
Erie, PA 16502 USA



Phone: 800-666-3691 or 814-452-3691
Fax: 800-456-1697 or 814-455-1697
www.reedmfgco.com